

# Energy Wall U-ERV 3600 Series

U-ERV 3600 Standard Features		Industry Standard Comparison
Airflow Range:	0 to 4500 CFM [3600 Rated]	Fully Variable ECM Fan Speed Modulation
Dimensions:	54" L X 32" D X 72" Height	1/3 Size of Comparable Units (12" Height per module)
Lightweight:	774 lbs.	92 lbs. per module for transport, 18.5 lb. per fan cube. 774 lb. total unit weight
AHRI 1060 Tested Core:	EWT-11-42 HWT-11-42	Counterflow plate-type, heat and humidity transfer Counterflow plate-type, heat-only transfer or condensing wrap-around application
Sensible Efficiency:	73% @ 3600 SCFM	Up to 90% Possible
Latent Efficiency:	63% @ 3600 SCFM	Up to 70% Possible
Total Efficiency:	69% @ 3600 SCFM	Up to 80% Possible
Exhaust Air Transfer:	Zero	Good for Bathroom Exhaust, Laboratories, Hospitals
Minimal Maintenance:	Filters @ 3-6 months	Total qty. 12, MERV 11: 5.00"x 40.5" x 2.0" (Nominal)
Stack Multiple Modules:	Vertical or Horizontal	Patented design - a single duct will connect to multiple U-ERVs
Fan Motors:	ECM	Variable Airflow adjustability & balancing with mechanical turn potentiometers Remote Variable Airflow adjustability via 0-10V signal
Antimicrobial Membrane:	Salt / Ceramic	Proven highly antimicrobial without the addition of additives. Actively kills bacteria flowing with both airstreams
Non-Fused Disconnect:	UL98 Rated	Lowers Installed Cost - Defeatable Lockout For Safe Access
Application:	Any Orientation	Universal Compatibility for Bolt-on, Roof-top, Exterior or Interior Installation
Electrical Power:	208 - 230 AC 3 Phase	VAC Input (50/60Hz)
Exterior Shell:	Polypropylene	Corrosion Proof, double wall construction Nano-particle metal-oxide insulation

Universal ERV/HRV 3600 Unit Data									
		External Static Pressure at 3600 CFM		Unit Data					
Model Number	Type	Supply (in. w.g.)	Exhaust (in. w.g.)	Module Weight (lbs.) (Ea.)	Fan Cube Weight (lbs.) (Ea.)	Total Unit Weight (lbs.)	Power 208 VAC 3Ø(Amps)		
							FLA	MCA	MOP
U-ERV-3600	Enthalpy	2.0	2.0	92	18.5	774	29.1	36.4	40
U-HRV-3600	Sensible								

# Energy Wall U-ERV 3600 Series

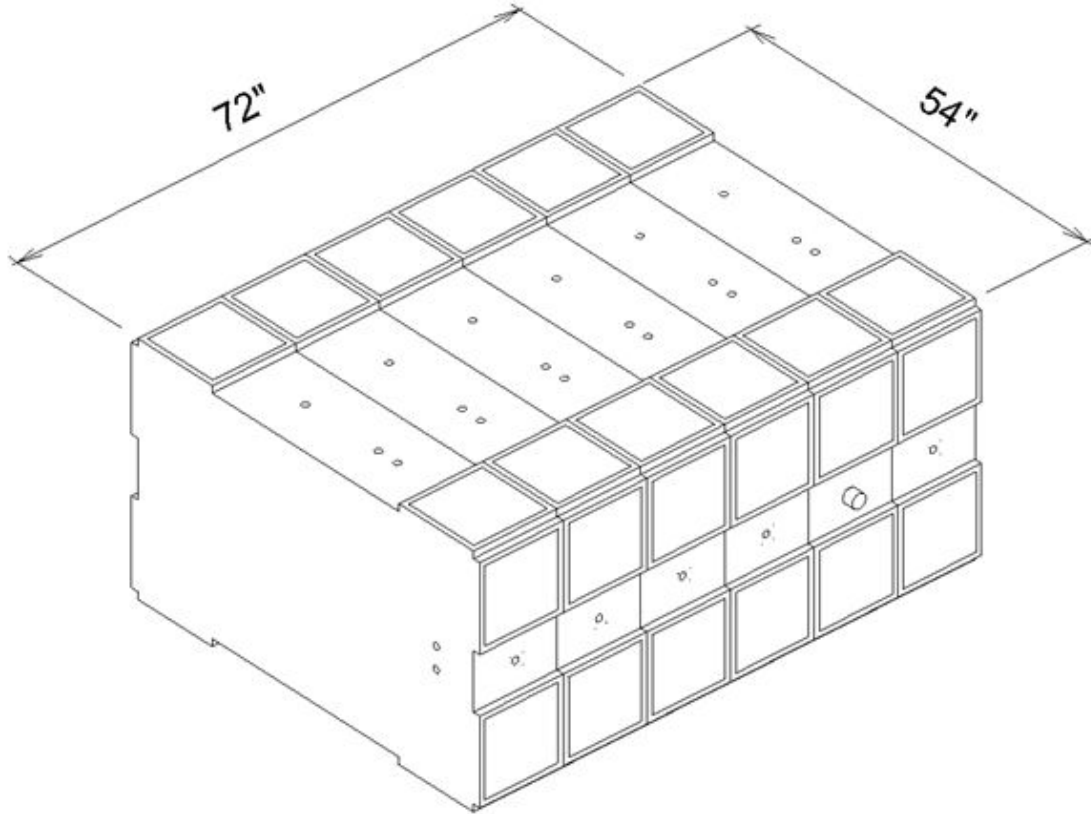

1002 New Holland Ave  
Lancaster PA 17601  
[www.energywall.com](http://www.energywall.com)